

Description:

Cylinder filling pump skid fully assembled and tested ready for connection, comprising;

- Actuated pump suction and return valve set
- Vessel connection hoses
- Krytem TLC range of cryogenic reciprocating cylinder filling pumps
- All associated instruments & safety devices
- Pump control panel
- Line safety manifold / distribution panel (see separate data sheet)
- Weather protection hood
- Fire shield for O2 version

Features:

- Inert or O2 variants
- 420 bar design
- Upto 16.5 liquid ltrs/minute flow rate
- 30Kw max power
- Facility for buffer cylinders
- Modular package ready for connection;
 - Reduced installation time = reduced cost
 - Reduced on site work = increased safety
- Fully factory tested module prior to despatch;
 - Reduced commissioning time = reduced cost
- Easy procurement – one item / one order = faster procurement / reduced cost

Options:

- Mono, dual or variable speed pump drives
- TLM version for O2 applications



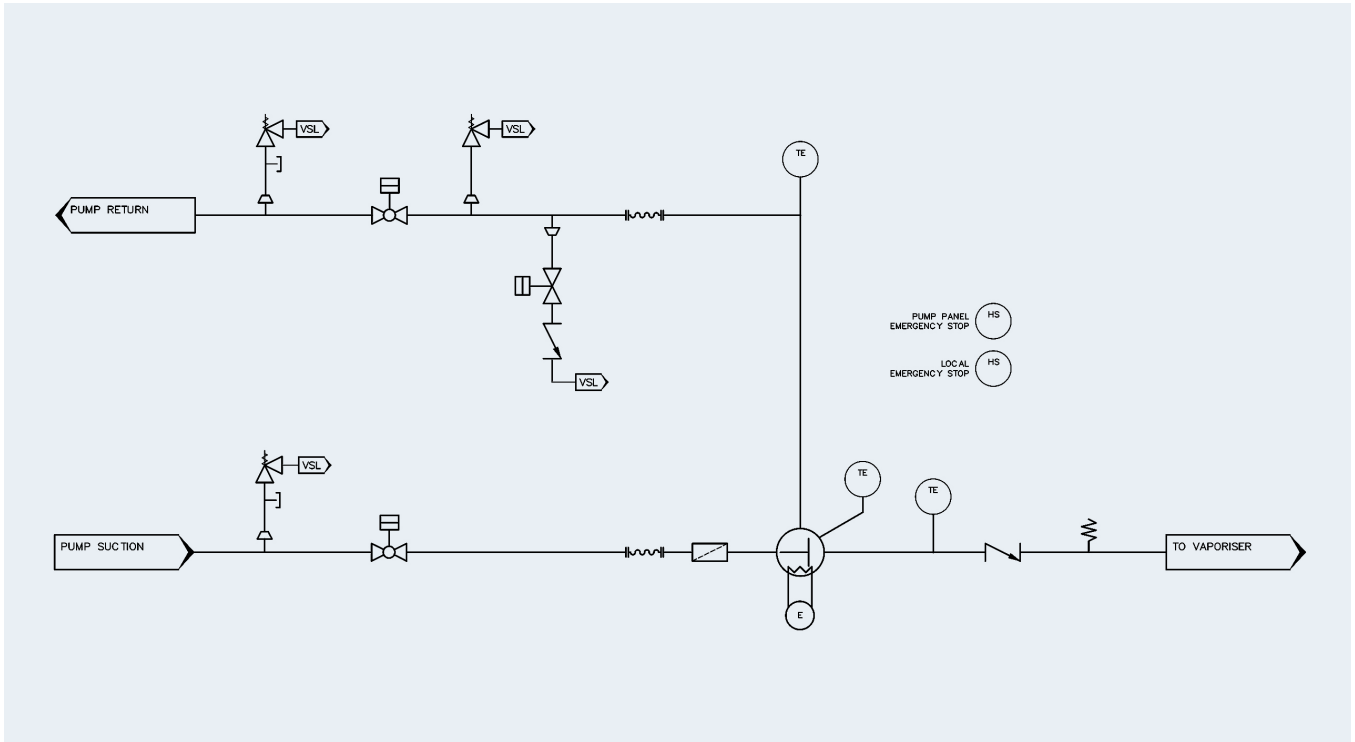

The information contained in this document is confidential, privileged and only for the information of the intended recipient and may not be used, published or redistributed without the prior written consent of iGAS Technology Solutions.